

### 工作項目

1. Check every equipment condition.
2. Back up hardware, software and download program to make sure line keep running.
3. Install Air Compressor Air curtain system and change switchgear.

### 內容摘要

BOPP I only have four lines that every lines represent 25% efficiency. Our maintenance jobs are keeping line no shutdown and increase output by upgrade hardware, software, route checking. In software part, we upgrade PLC programmer, logix 500 to 5000, to get faster computing speed. In hardware part, we install new system, air curtain, it promote our film quality and decrease start time. Normally we inspect our equipment everyday like temperature, speed, spark...etc.

### 實習成果

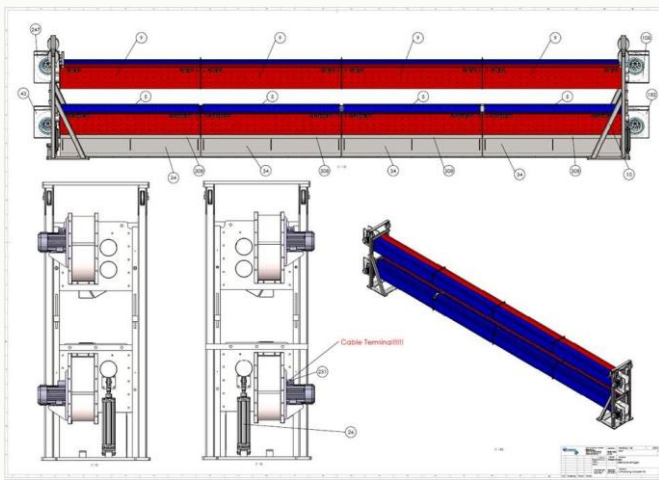

Air curtain system

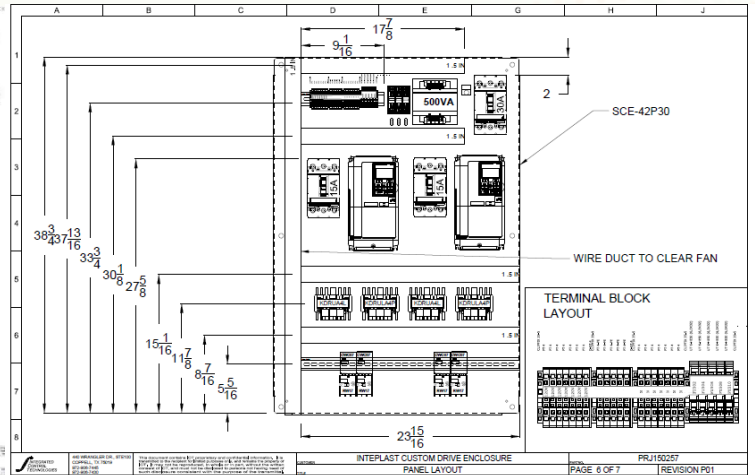

Parts layout

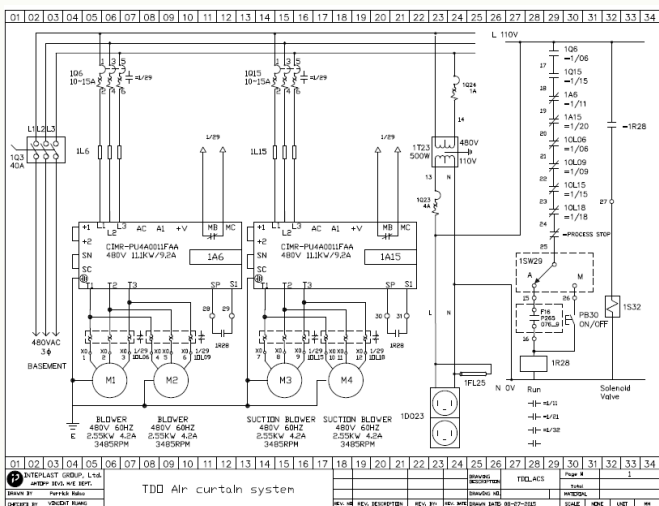

Control panel wiring drawing



The place mount air curtain system.

A lot parameters are depend on temperature such as tension, plating temperature, roll speed...etc. The film comes from die and through MTO, TDO which stretch film in very hot condition. The air curtain system main features are cooling and detect film status which mounted after TDO.

### 電機工程

姓名：蕭銘榮

實習公司：Inteplast Group

指導主管：Jerry Wu

實習單位：BOPP I MAINT 實習期間：2013/09/17~104/09/16 輔導老師：張嘉德